

**PLAN TO ACCOMPANY A
NOTICE OF INTENT
ROWLEY, MA
18 WEST OX PASTURE LANE**

SCALE: 1"=20' OCTOBER 10, 2023

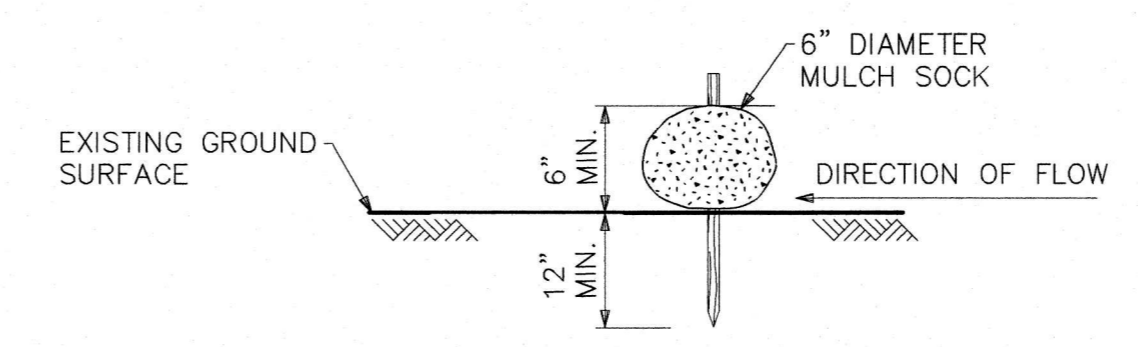

Richard L. Williams
10-10-2023



**MULCH SOCK
DETAIL
(NOT TO SCALE)**

LEGEND OF ABBREVIATIONS & SYMBOLS

EXISTING 2-FOOT CONTOUR	98
EXISTING 10-FOOT CONTOUR	100
EXISTING RETAINING WALL/STONE WALL	
EXISTING FENCE CHAIN LINK	
EXISTING FENCE VINYL	
EDGE OF BVW	
25' BUFFER ZONE TO BVW	25
50' BUFFER ZONE TO BVW	50
100' WETLAND BUFFER ZONE	100
AC UNIT	
ELECTRIC METER	
CONIFEROUS TREE	
DECIDUOUS TREE	
GARAGE FLOOR	G.F.
PROPOSED CONTOUR	
PROPOSED MULCH SOCK	
PROPOSED EDGE OF LAWN	
PROPOSED FENCE	

ZONING DISTRICT: OUTLYING

MINIMUM LOT AREA = 60,000 S.F.
 MINIMUM LOT FRONTAGE = 150 FEET
 MINIMUM LOT WIDTH (AT FRONT SETBACK LINE) = 100 FEET
 MINIMUM LOT WIDTH = 40 FEET
 MINIMUM LOT PERIMETER = 1 FT PER 39.6 S.F.
 FRONT YARD SETBACK = 50 FEET
 SIDE YARD SETBACK = 15 FEET
 REAR YARD SETBACK = 15 FEET
 MAXIMUM BUILDING LOT COVERAGE = 25%
 MAXIMUM HEIGHT = 35 FEET



**LOCUS MAP
SCALE: 1"=500'±**

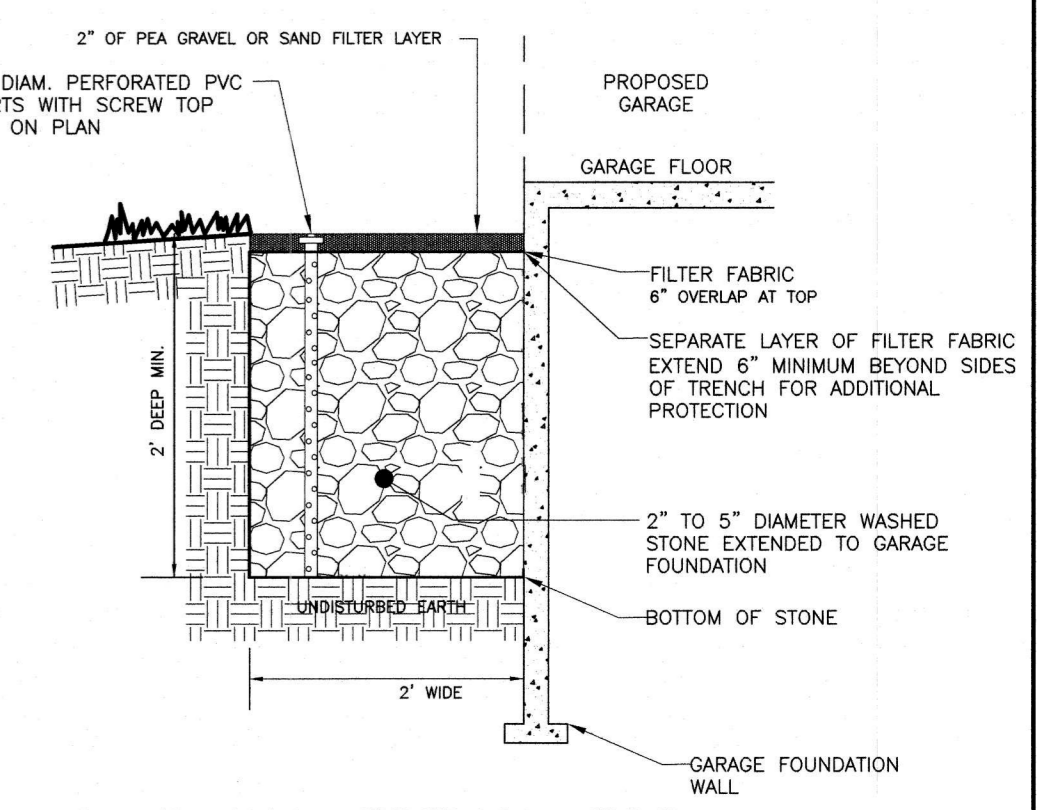
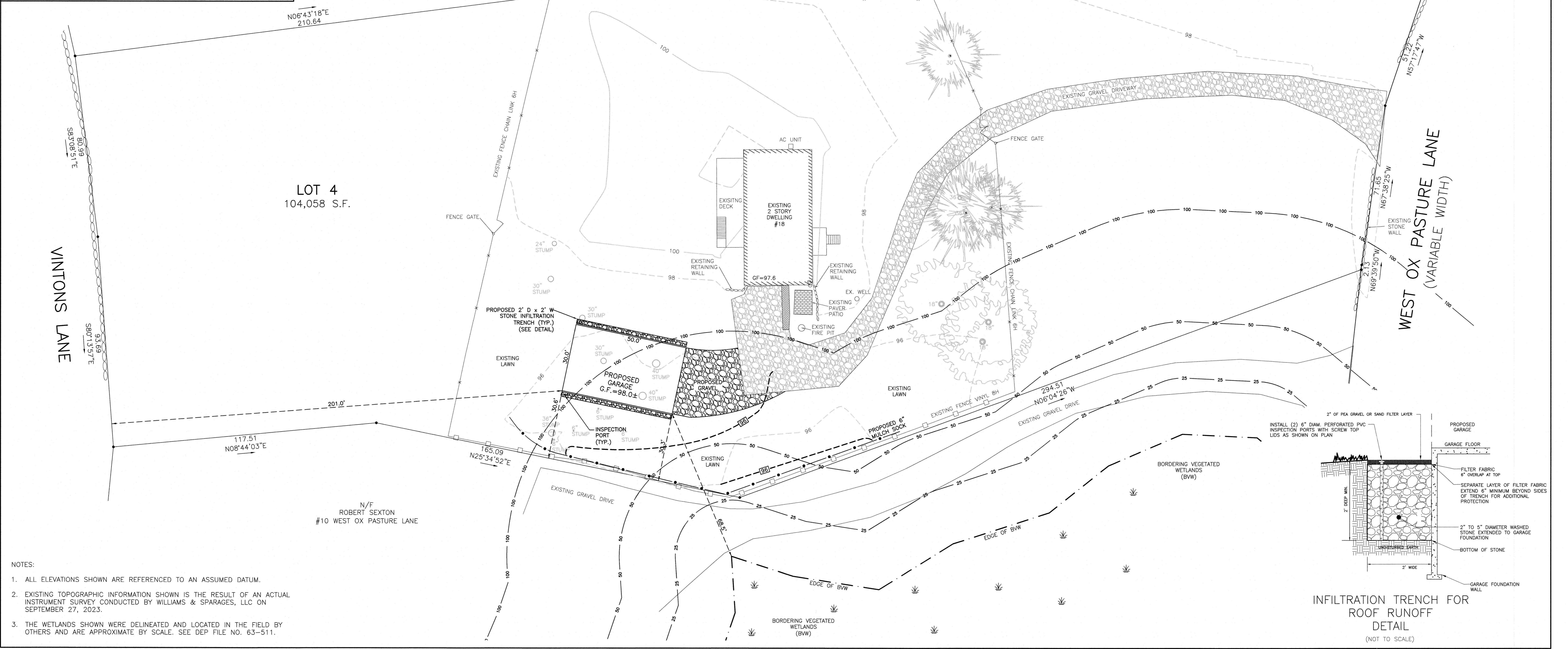

**INFILTRATION TRENCH FOR
ROOF RUNOFF
DETAIL
(NOT TO SCALE)**

- NOTES:**
1. ALL ELEVATIONS SHOWN ARE REFERENCED TO AN ASSUMED DATUM.
 2. EXISTING TOPOGRAPHIC INFORMATION SHOWN IS THE RESULT OF AN ACTUAL INSTRUMENT SURVEY CONDUCTED BY WILLIAMS & SPARAGES, LLC ON SEPTEMBER 27, 2023.
 3. THE WETLANDS SHOWN WERE DELINEATED AND LOCATED IN THE FIELD BY OTHERS AND ARE APPROXIMATE BY SCALE. SEE DEP FILE NO. 63-511.